



Item	Page
Introduction	2
Pneumatic Telescopic Masts	3
Table Data NH Series	4
Table Data NK Series	4
Table Data NL Series	5
Table Data NX Series	6
Table Data NY Series	7
FM Series	8
Non Standard Masts	8
Lightweight Push-Up Mast	9
TPM Mast	9
Composite Push Up Mast	9
General Accessories	10
Magnetic Safety Switch	10
Mast Covers	10
Cable Guides	10
Cable Supports	10
Mounting Brackets	10
Vehicle Bearings	11
Base Guy Assembly	11
Tripod Stand	11
Field Stand	11
Top Guy Assembly	12
Climbing Steps	12
Rotation Handles	12
Antenna Adapter	12
Ground Stakes	12
Ground Pegs	12
Air Supply Equipment	13
Compressor Information Table	13
NC1 Compressor	13
NC2 Compressor	13
NC3 Compressor	14
Remote Controls	14
Foot Pumps	14
Installation Dimensions	15
Pneumatic Mast Trailers	16
Vehicle Installation	17
Rapid Deployment Unit	18
Winch Operated Masts	19
WTM Trailer Masts	20
Accessories	20
Tilt Over Mechanism	20
Base Guy Assembly	21
Hand Winch	21
Electric Winch	21
Extension Tubes	21
Side Mounting Brackets	21
HiloCAM2	22
Typical Mast Applications	24
Standard Mast Quick Reference Chart	25
Standard Mast Quick Reference Details	26

Hilomast was incorporated over 35 years ago. Since that time there has been a continuous improvement, both in the design and manufacture of the product. It is SMC's policy to ensure products meet the current demands of users in both civil and military applications.

The Hilomast range of pneumatic telescopic masts are approved to international Mil Std 810E environmental standard for operation and storage, including low pressure (high altitude) operation. The investment in Mil Std by South Midlands Communications, combined with the provision of a comprehensive installation, design and customisation service, has allowed the company to become a major supplier in the international defence, security, broadcast and general communication markets.



All masts built in our factory are assembled using components of the highest quality ensuring the highest reliability is maintained. Where changes are made to the design, complete testing is carried out to ensure that these changes do not have an adverse effect on the products life, it's use and of course, the safety of the user.

SMC's capability to design complete communications systems, including Hilomast products, has secured major contracts, offering the establishment of reliable, easy to use long range communications.

SMC believe their range of masts offer the widest choice available on the world market, with extended heights from 5 to 30 metres and with trailer mounted, transportable and vehicle mounted options.

# Pneumatic Telescopic Masts

## Mk II Range

Hilomast has long been established as a world leader in pneumatic mast technology and in addition to providing a supporting mast for mobile or semi-permanent communications systems, the product is particularly appropriate to those involved in security, surveillance and high level filming or camera work.

Many applications require a mast which is quick and easy to erect or retract. Hilomasts are designed and robustly constructed from heat treated aluminium alloy to meet these needs and to withstand the demands placed upon the masts under field conditions, extreme climatic variation or environmental changes. Seals have an operating temperature range between -30°C to +70°C in dry atmospheric conditions.

The Hilomast MKII range can be extended by using low pressure air which is supplied either from a compressor or, in the case of smaller masts, from a footpump.

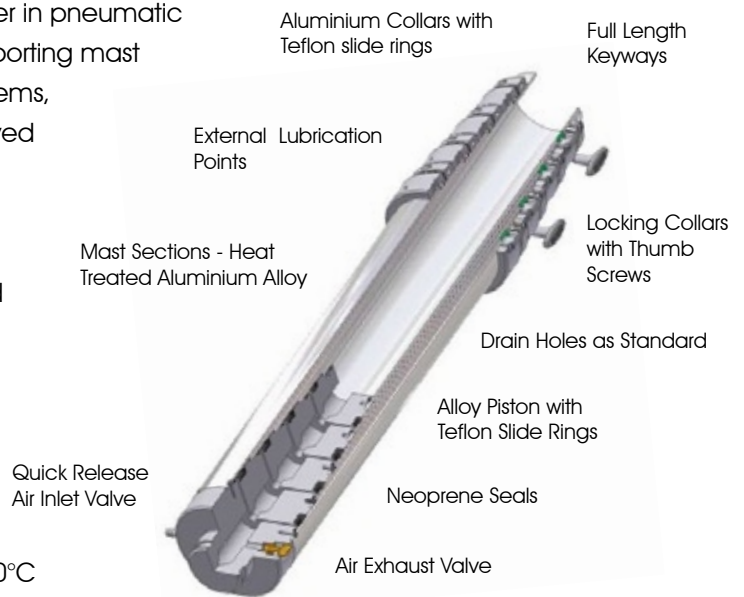

A full length keyway is machined in each of the extending tubes to prevent relative rotation between them. With the sections partly or fully extended the masts can be rotated to the required direction and then clamped.

The MKII range includes 5 series of masts, ranging from 5 to 30 metres and have been developed from the previously successful MKI design - with additional benefits and features including easy to use locking handles for locking, external lubrication nipples for simple maintenance and quick fitting inlet valves.

With such a wide variety of applications and methods of mounting, masts are supplied as basic pneumatic units. When ordering, it is essential to specify the type of mast, mounting arrangement and accessories required.



## NH Series

The NH Series of telescopic Hilomasts has a base section diameter of 89mm and is pneumatically operated with either a manual footpump or small compressor. Although the smallest in the range, they are robust and ideal for applications where portability is of prime importance. Easily fitted to a vehicle, the masts are suited to mobile applications where light antennas are required. The top section diameter is specified in the table for the fitting of antennas. Locking and non locking masts available.

Mast	Height Extended	Height retracted	Number of Sections	Diameter of Top Section	Vertical Head Load	Max Wind Speed Unguyed	Max. Wind Speed with Top Guys	Top Guy Ref. No. inc. Stakes	Basic Weight of Mast
	metres	metres		mm	kgs	kph	kph		kgs
NH5	5	1.41	5	38	18	180	180	NUG/1GS	15
NH5NLC	5	1.41	5	38	18	180			15
NH7	7	1.84	5	38	15	135	160	NUG/1GS	19
NH7NLC	7	1.84	5	38	15	135			19
NH9	9	2.3	5	38	13	108	147	NUG/3GS	23
NH9NLC	9	2.3	5	38	13	108			23

## NK Series

The NK Series of telescopic Hilomasts has a base section diameter of 102mm and is pneumatically operated by either a manual footpump or small compressor. Although designed for long life commercial applications, the NK Series is equally suited for experimental work. The top section diameter is specified in the table for the fitting of antennas. Locking and non locking masts available.

### Typical Uses

- » Radio communications
- » Field strength measurements
- » Supporting cameras
- » Anemometers, microphones, temporary floodlighting and survey equipment

Mast	Height Extended	Height retracted	Number of Sections	Diameter of Top Section	Vertical Head Load	Max Wind Speed Unguyed	Max. Wind Speed with Top Guys	Top Guy Ref. No. inc. Stakes	Basic Weight of Mast
	metres	metres		mm	kgs	kph	kph		kgs
NK6	5.9	1.64	5	50	27	164	164	NUG/2GS	21
NK6 NLC	5.9	1.6	5	50	27	164			21
NK9	9	2.3	5	50	22	114	137	NUG/2GS	26
NK9 NLC	8.9	2.3	5	50	22	114			26
NK11	10.9	2.37	6	38	18	96	125	NUG/3GS	29
NK11 NLC	10.6	2.3	6	38	18	96			29
NK16	16	4	5	50	20	65	112	NUG/4GS	44
NK16 NLC	16	4	5	50	20	65			44

1. The tables show the vertical head load that each mast will support and the maximum operational wind speed. The weight of the antenna, however, is not usually the main criterion when selecting a mast. The limiting factor is usually the 'side surface area' of the antenna.

The wind speeds shown are based on the following side surface areas:

NH Masts = 1000 sq. cms. NK = 1400 sq. cms. NL = 2000 sq. cms. NX = 3000 sq. cms. NY = 11000 sq. cms.

Although the masts will support antennas with a larger side surface area than that shown, the maximum operational wind speed will be correspondingly reduced. If in doubt, please ask for a computer check against your specific application.

\* Top guys not recommended. † with non rotating base plate.

The NL Series of telescopic Hilomasts has a base section diameter of 127mm and is pneumatically operated by a compressor. The shorter models in this series can be operated by footpump. Being heavier than the NK Series, it will support larger antennas under more adverse weather conditions. Although these masts can be used for portable applications, they are primarily designed for vehicle installation, either bracketed to the rear, or mounted through a roof bearing.

Models NL16 and NL22 can be mounted onto the roof of a vehicle using a sliding roof carriage. The carriage slides rearwards and the mast is then tilted and clamped in the vertical position. Masts NL8, NL12 and NL22 have a top section diameter of 50mm for attaching antennas. Masts NL9, NL10 and NL16 have a top spigot of 50mm diameter x 130mm long. Locking and non locking masts available.

Mast	Height Extended	Height Retracted	Number of Sections	Diameter of Top Section	Vertical Head Load	Max Wind Speed Unguyed	Max. Wind Speed Guyed	Top Guy Ref. No. inc. Stakes	Basic Weight of Mast
	metres	metres		mm	kgs	kph	kph		kgs
NL8	7.9	1.77	7	50	25	140	140	NUG/2GS	34
NL8 NLC	7.5	1.77	7	50	25	140			34
NL9	8.8	2.44	5	76	35	130	130	NUG/6GS	37
NL9 NLC	8.5	2.7	5	76	35	130			37
NL10	10.5	2.5	6	63	27	110	120	NUG/5GS	41
NL10 NLC	10.2	2.3	6	63	27	110			41
NL12	12.2	2.43	7	50	25	95	110	NUG/4GS	46
NL12 NLC	11.9	2.4	7	50	25	95			46
NL16	15.6	4.15	5	76	23	78	102	NUG/6GS	61
NL16 NLC	15.6	4	5	76	23	78			61
NL22	21.7	4.15	7	50	14	56	92	NUG/8GS	74
NL22 NLC	21.7	4.1	7	50	14	56			74



1. The tables show the vertical head load that each mast will support and the maximum operational wind speed. The weight of the antenna, however, is not usually the main criterion when selecting a mast. The limiting factor is usually the 'side surface area' of the antenna.

The wind speeds shown are based on the following side surface areas:

NH Masts = 1000 sq. cms. NK = 1400 sq. cms. NL = 2000 sq. cms. NX = 3000 sq. cms. NY = 11000 sq. cms.

Although the masts will support antennas with a larger side surface area than that shown, the maximum operational wind speed will be correspondingly reduced. If in doubt, please ask for a computer check against your specific application.

\* Top guys not recommended. † with non rotating base plate.

The NX Series of telescopic Hilomasts has a base section diameter of 152mm and is pneumatically operated by a compressor. Being heavier than the NL Series, it will support larger antennas and should be considered as being the maximum size necessary for general use. Although the NX Series can be used for portable applications, it is primarily designed for vehicle installation, either bracketed to the rear, or mounted through a roof bearing. Models NX18, NX25 and NX30 can be mounted onto the roof of a vehicle using a sliding carriage. The carriage slides to the rear of the vehicle, the mast is then tilted and clamped in the vertical position. All masts in this NX Series can be trailer mounted.

The NX30 has a top section diameter of 50mm for attaching the antenna. All other NX masts have a top spigot of 50mm diameter x 130mm long. Locking and non locking masts available.

Mast	Height Extended	Height Retracted	Number of Sections	Diameter of Top Section	Vertical Head Load	Max Wind Speed Unguyed	Max. Wind Speed Guyed	Top Guy Ref. No. inc. Stakes	Basic Weight of Mast
	metres	metres		mm	kgs	kph	kph		kgs
NX8	7.6	1.91	7	76	50	155	155	NUG/6GS	50
NX8 NLC	7	1.7	7	76	50	155			50
NX10	10.1	2.51	6	89	50	120	120	NUG/7GS	60
NX10 NLC	9.7	2.3	6	89	50	120			60
NX14	13.6	2.64	8	63	35	92	95	NUG/5GS	70
NX14 NLC	13	2.4	8	63	35	92			70
NX18	18.5	4.32	6	89	30	70	83	NUG/10GS	93
NX18 NLC	18.5	4.2	6	89	30	70			93
NX25	25	4.44	8	63	20	52	80	NUG/9GS	110
NX25 NLC	25	4.3	8	63	20	52			110
NX30	29.8	4.57	9	50	14	44	75	NUG/8GS	120
NX30 NLC	29	4.4	9	50	14	44			120



1. The tables show the vertical head load that each mast will support and the maximum operational wind speed. The weight of the antenna, however, is not usually the main criterion when selecting a mast. The limiting factor is usually the 'side surface area' of the antenna.

The wind speeds shown are based on the following side surface areas:

NH Masts = 1000 sq. cms. NK = 1400 sq. cms. NL = 2000 sq. cms. NX = 3000 sq. cms. NY = 11000 sq. cms.

Although the masts will support antennas with a larger side surface area than that shown, the maximum operational wind speed will be correspondingly reduced. If in doubt, please ask for a computer check against your specific application.

\* Top guys not recommended. † with non rotating base plate.

The NY Series of telescopic Hilomasts has a base section diameter of 238mm and is pneumatically operated using a suitable compressor. These masts are available with locking collars fitted as an option. Standard NY masts have special engaging screws fitted into each of the main collars to resist the torsional loads when the masts are fully extended. The NY Series of masts is for special applications where high head loads are required or where maximum directional stability is necessary.

### Typical Uses

- » Mounting video cameras fitted with telephoto lenses
- » Microwave dish antennas for Electronic News Gathering/Outside Broadcast
- » Direction sensitive antennas or devices

A computer calculation can be made for maximum deflection on specific applications.

Mast	Height Extended	Height retracted	Number of Sections	Diameter of Top Section	Vertical Head Load	Max Wind Speed Unguyed	Max. Wind Speed with Top Guys	Top Guy Ref. No. inc. Stakes	Basic Weight of Mast
	metres	metres		mm	kgs	kph	kph		kgs
NY7	6.7	1.62†	7	114	120	150	*	–	88
NY10	9.6	2.22†	6	127	100	126	*	–	106
NY12	12.7	2.31†	8	102	90	90	*	–	120
NY14	14.3	2.35†	9	89	70	80	*	–	127
NY18	17.7	3.96†	6	127	50	83	*	–	170
NY21	20.7	4.00†	7	114	40	67	*	–	183

For large diameter antennas, it is important to ensure that the torsional loads transmitted to the masts when fully extended do not exceed the following:

NY7 and NY21 = 5200kg.cms.

NY10 and NY18 = 5800kg.cms. NY12 and NY14 = 4300kg.cms.

All NY masts have a horizontal flange of 150mm diameter at the top for mounting antennas etc.

This flange can be drilled to suit customer requirements.



1. The tables show the vertical head load that each mast will support and the maximum operational wind speed. The weight of the antenna, however, is not usually the main criterion when selecting a mast. The limiting factor is usually the 'side surface area' of the antenna.

The wind speeds shown are based on the following side surface areas:

NH Masts = 1000 sq. cms. NK = 1400 sq. cms. NL = 2000 sq. cms. NX = 3000 sq. cms. NY = 11000 sq. cms.

Although the masts will support antennas with a larger side surface area than that shown, the maximum operational wind speed will be correspondingly reduced. If in doubt, please ask for a computer check against your specific application.

\* Top guys not recommended. † with non rotating base plate.

## FM Series

One of the main problems with floodlighting masts is the electric cable having to safely travel the full length of the extended mast, and be conveniently stored when retracted.

The FM Series of Hilomast has solved both these problems in a neat and practical way. A coiled cable enters the mast through a special gland in the base and extends inside the mast to the top, where it exits into a junction box for lighting connections. The memory in the cable allows it to extend and retract with the mast.

With the obvious advantages of a pneumatic telescopic mast, the 'FM' System is one of the market leaders in this field.

There are three standard models in this series, all with a base diameter of 115mm. Each has an inner cable with four cores of 2.5mm/sq., and is complete with a rainshield, rotation handles, pressure relief valve and mast extension warning switch. Other cable configurations available.

Mounting is by side mounting brackets NSM/115, or vehicle roof bearing kit NRB/115. Extension is by compressor or foot pump.

As these masts are usually used in situations of short duration, they do not have locking collars or top guys as standard but these are available if required.



Mast	Height Extended	Height Retracted	Number of Tubes	Toptube Diameter	Vertical Head Load	Maximum Windspeed	With Top Guys	Mast Weight
	metres	metres		mm	kgs	kph	kph	kgs
FM5	4.7	1.63	5	63	45	170	206	25
FM6	6.6	2.02	5	63	36	130	130	29
FM8	8	2.31	5	63	28	115	115	33

Wind speeds calculated on maximum vertical load with side surface area of 3200 sq.cms.

## Non Standard Masts



The Hilomast range is designed and built around modular components, which allows non standard configurations to be easily and quickly provided to meet particular customer requirements.

SMC have designed software that can be used to produce custom mast solutions where standard products are not appropriate.

## TPM

The SMC push up mast is a lightweight version of the Hilomast. It has been designed so that it can be used as either a hand operated push up mast or pneumatically assisted mast. Deployment of the pneumatic version can be carried out by either using a footpump or one of the SMC NC1 range of compressors, shown in this catalogue (page 12).

There are several mounting arrangements available for the installation of masts. They can be mounted externally to a vehicle or building. For erecting masts on open ground, base guy assemblies are available, which are best suited for green-field mounting. A rapid deployment unit is available for all sizes of TPM, which can be held under the wheel of a vehicle.

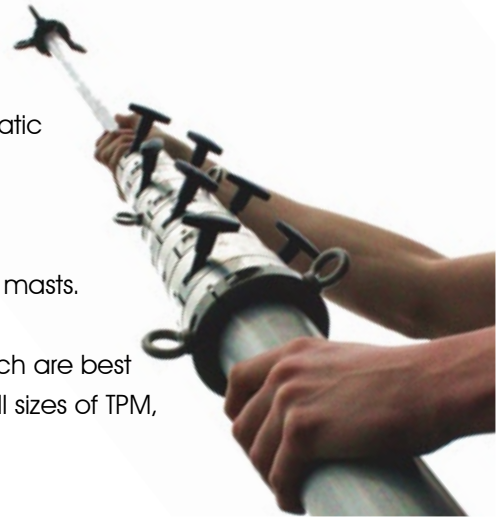

Mast	Retracted Height	Extended Height	Vertical Headload	Maximum Wind Speed Unguyed	Maximum Wind Speed c/w Top Guys	Surface Area
	Metres	Metres	Kgs	Km/h	Km/h	cm <sup>2</sup>
TPM8	1.47	8	10	75	120	1000
TPM10	1.75	10	8.50	65	100	1000
TPM12	2.02	12	7	55	85	1000

## Composite Push Up Mast



The PFC series of the telescopic masts have a base section diameter of 88.7mm and are operated by hand. The mast sections are made of a fibreglass/carbon fibre sandwich that gives a very light weight, durable mast. Each section has a locking collar and dampening valves that control the speed at which the mast is lowered. The mast is designed for portable applications such as mobile communication equipment.

Mast	Height Extended	Height Retracted	Number Of Sections	Diameter Of Top Section	Diameter Of Base Section	Vertical Headload	Max. Wind Speed Unguyed	Max. Wind Speed With Top Guys	Basic Weight Of Mast *
	(m)	(m)		(mm)	(mm)	(kg)	(kph)	(kph)	(kg)
PFC 7.5	7.3	1.92	5	65.6	85.6	12	N/A	120	6
PFC 9	9.03	2	6	60.6	85.6	10	N/A	100	7
PFC 12	12.4	2.1	8	50.6	85.6	9	N/A	85	9

\*Excluding Guy Kits

## Extension Warning Switch

The purpose of this switch is to give an audio or visual warning that the telescopic mast has not been fully retracted. When fitted in a vehicle, it can be used via a relay to interrupt the ignition circuit and prevent movement of the vehicle when the mast is not retracted. It is fitted to the outer tube of the mast and is operated by a set of magnets placed at the bottom of the inner mast tube. The magnets are bonded into an aluminium housing and can be easily inserted into the top section of the mast without any dismantling. The plastic end cap of the top section is removed and the magnet housing is pushed down the tube with a rod. It is automatically retained in position by a neoprene 'O' ring fitted to it.

To determine the size of magnetic housing, refer to table for diameter of top section.

eg: For NL12 the top section diameter is 50mm = Switch ref:

**MAG/50**

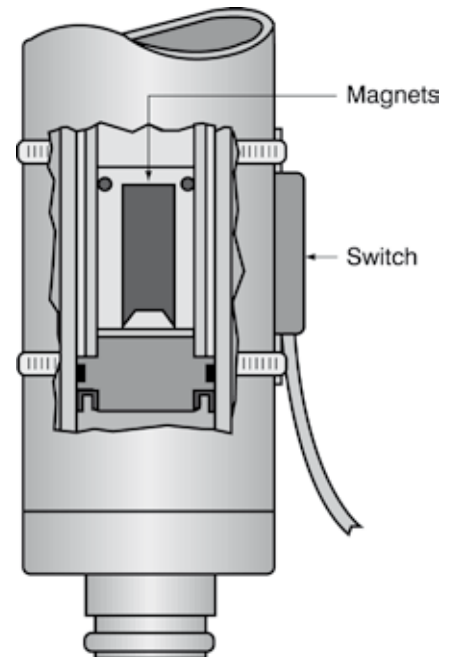

## Mast Covers

For weather protection when the mast is not in use. Made of strong waterproof material. Fits over the collars and is secured to the mast by means of a strap.

**NHB for NH masts**

**NKB for NK masts**

**NLB for NL masts**

**NXB for NX masts**

**NYB for NY masts**

## Cable Guides

These stainless steel cable guides screw into tapped holes especially provided in each mast collar. They will permit feeder cables of up to 12mm dia. to be attached to the mast without disconnecting the end terminations. Eye 26mm dia. (Supplied complete with locknuts).

**CG2612**

## Cable Supports

Can be used as clamps or guides for feeder cables. Supplied in sets, together with stainless steel screws for fitting to mast collars. The clips are nylon and spring over the cable after it is connected. Two sizes are available.

**CS3329 Eye 14mm dia.**

**CS3343 Eye 30mm dia.**

## Mounting Brackets

For mounting masts to the vertical surface of a vehicle or building the kit comprises two brackets.

The aluminium top bracket has one half detachable to allow for removal of the mast without disturbing the bracket fixings. It incorporates Teflon bearing rings to protect the mast.

The lower bracket has a Teflon disc to permit easy rotation of the mast and a thumb screw for locking it in any desired azimuth position. On the NX and NY Series, the bracket is galvanised steel, onto which is bolted an aluminium base plate with a collar brake. (Hole centres NH, NK and NL masts 150mm for M10 bolts. NX masts 160mm for M12 bolts and NY masts 200mm for M12 bolts).



NK

NX

**NSM/89 for NH masts**

**NSM/127 for NL masts**

**NSM/238F for NY masts**

**NSM/238R rotating version for NY masts only**

**NSM/102 for NK masts**

**NSM/115 for FM masts**

**NSM/152 for NX masts**

## Vehicle Bearings

For mounting masts through the roof of a vehicle. The assembly comprises an upper and lower aluminium bearing. The upper has three separate components, a flange fitted with a Teflon ring that is bolted to the outer skin of the vehicle, a tapping plate and a weatherproof shield that clamps to the mast. The lower bearing base plate has a Teflon disc to permit easy rotation of mast and a thumb screw for locking it in position. The NX and NY have a collar brake fitted. The base plate is bolted to the floor with 4-M12 bolts spaced on 140mm P.C.Dia. There are two variants for NY, either for rotating or non-rotating masts.



NK

NX

<b>NRB/89 for NH masts</b>	<b>NRB/102 for NK masts</b>
<b>NRB/115 for FM masts</b>	<b>NRB/127 for NL masts</b>
<b>NRB/152 for NX masts</b>	<b>NRB/238F for NY fixed</b>
<b>NRB/238R for NY rotating</b>	



## Base Guy Assembly

This arrangement is generally the easiest method of erecting a mast on open ground. The kit is complete with mast fittings, 3 guys, adjusters, base plate, ground stakes and pegs. Foundation bolts can be supplied for mounting on concrete foundations. The base plate incorporates a Teflon disc to permit rotation of mast and a thumb screw for locking in any desired azimuth position.

The NH and NK kits have polyester guy ropes and special 'one way' adjusters that allow the mast to be set vertically, while still supporting it by hand.

The NL and NX kits have galvanised wire guy ropes and conventional rigging screws.

<b>NBG/89 for NH masts</b>	<b>NBG/102 for NK masts</b>
<b>NBG/127 for NL masts</b>	<b>NBG/152 for NX masts</b>

## Tripod Stand

This tripod is designed for the free standing of NH Series masts on hard surfaces. It is constructed of steel and folds into a compact unit for storage and transit. It can also be easily detached from the mast. The mast can be rotated and locked in any position and the feet are adjustable to suit uneven ground. The stand is intended for use in light winds only and should not be left unattended. Top guys are required for windy conditions. Weight 17kgs. Radius of legs 1,300mm.



**NTRY/89 for NH masts only**

Top guys should be fitted at wind speeds above 40 kph. For NK16 mast, top guys are required at all wind speeds.



## Field Stand

This four legged stand is for field erection of NK Series masts.

Constructed from aluminium alloy, it has adjustable legs for irregular ground conditions. These fold into the mast for transit. Ground pegs are supplied for anchoring the feet and base plate. The top bearing and base plate permit the rotation of the mast and a thumbscrew locks it in any desired azimuth position.

Weight 12 kgs.

Note: For NK6, NK9 and NK11 masts, top guys should be fitted at wind speeds above 40 kph. For NK16 mast, top guys are required at all wind speeds.

**N4L/102 for NK masts only**

## Top Guy Assembly

For use in inclement weather conditions or to give more directional stability to the top of the mast. In some cases masts will then withstand higher wind speeds(See Table). This assembly comprises a detachable aluminium guy collar, D shackles, 3 pre-stretched polyester guys (5mm dia.) fitted with rope grips and nylon adjusters. The guy collar is designed to clamp to the upper end of the second from top section of mast.

The top guy assembly includes three GS1 ground stakes for supporting the guy ropes.

For Ref. No. see main tables (page 5/6)



## Climbing Steps

These are useful for field applications, providing easy access to locking collars and antennas.

They clamp in any position on the mast lower section and fold upright for transit. Single steps for climbing. Double steps for resting.



	Single Step	Double Step
For NK masts	NSP/102/1	NSP/102/2
For NL masts	NSP/127/1	NSP/127/2
For NX masts	NSP/152/1	NSP/152/2

## Rotation Handles

These are useful for field applications, providing easy access to locking collars and antennas.

They clamp in any position on the mast lower section and fold upright for transit. Single steps for climbing. Double steps for resting.

NRH/89 for NH masts
NRH/102 for NK masts
NRH/127 for NL masts
NRH/152 for NX masts
NRH/238 for NY masts



## Antenna Adapter

This zinc plated steel adapter will support antennas horizontally or vertically, with boom diameters up to 40mm.

Ref: SMC 63



## Ground Stakes

Fabricated from steel angle with reinforced cap. Finish Hot dip galvanised.

Length 750mm.

Weight 2.3 Kgs.

Part No. 300214304

## Ground Pegs

For base plate or field stand.

Galvanised steel.

Length 300mm. Weight 0.3 Kgs.

Part No. 260201004

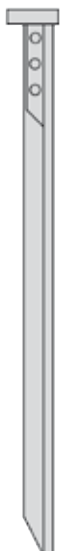

NOTE: The above listed mountings and accessories are all standard parts. Other accessories are available to suit customer's special requirements. Details on request.

Hilomast compressors are air cooled, oil-less and of the diaphragm type. They have steel cases and are powered by electric motors. All models incorporate a pressure controlled switch to maintain the correct mast working pressure. They are quiet, maintenance free and assembled from components that have a proven reliability over many years.

Compressor Type	Approx. rate of mast extension Metres per minute				
	NH Series	NK Series	NL Series	NX Series	NY Series
NC1	7.2	4.2	2.6	1.7	–
NC2	13.5	8.1	4.8	3.2	1.7
NC3	–	18.1	10.8	7.5	3.9

To calculate time to fully extend mast;  
 The height of mast is divided by rate  
 e.g. For NL/12 mast with NC/2  
 Compressor - Extension Time =  $12 \div 4.8$   
 = 2.5 minutes.  
 The time to reach max. pressure is  
 approx. 2 x Extension Time e.g. 5 minutes.

Note: To extend the larger NY Series masts at a faster rate than shown in table, higher capacity units can be constructed to suit customers requirements. Due to low pressures needed to extend masts, under no circumstances should standard commercially available compressors be used without consultation with SMC.

## NC1 Compressors

The NC1 compressor is the smallest and simplest in the Hilomast range. They are portable and thus suitable for field applications. The units are supplied complete with a single hose and mast connector. The mast is retracted by a manual exhaust valve on the front of the unit, enabling full control from inside a vehicle or building. Although designed primarily for the NH and NK Series masts, they will perform satisfactorily with the NL Series, when the speed of extension is not important (See table).

Specification	
NC1/230 for 220/240v AC	Output: 17 litres/minute at 0.7Kg/cm <sup>2</sup> Max. Pressure: 1.8 Kg/cm <sup>2</sup> Weight: 13.2 Kgs. Size: 300 x 320 x 210mm high
NC1/12 For 12v DC supply NC1/24 For 24v DC supply	Output: 17 litres/minute at 0.7Kg/cm <sup>2</sup> Max. Pressure: 1.8 Kg/cm <sup>2</sup> Weight: 8 Kgs. Size: 290 x 145 x 210mm high



## NC2 Compressors

The NC2 compressor has all the features of the NC1 compressor and gives approximately twice the output. An additional feature is a single switch that controls both power supply and an electrically operated exhaust valve.

The units are supplied with two hoses, one for connection to mast and one for exhaust air and drainage. This feature is very useful for vehicle installation, as it drains the moisture collected in the mast from the compressor. The NC2 compressors are ideally suited for the NL Series masts but will work equally well with the NK and NX Series. (see table)

Specification	
Max. Pressure: 1.8 Kg/cm <sup>2</sup> Weight: 15 Kgs. NC2/230 for 220/240v AC	Output: 34 litres/minute at 0.7Kg/cm <sup>2</sup> Size: 330 x 320 x 220mm high
Single phase supply	Current: 1 amp
NC2/12 For 12v DC supply	Current: 14 amps
NC2/24 For 24v DC supply	Current: 8 amps



Remote controls are available as an optional extra.

## NC3 Compressors

The NC3 compressor is the largest in the Hilomast range. Although designed for NX and NY Series masts, they can be used to operate smaller masts where a faster rate of extension is required (see table) They have the same type of switch and hose arrangement as the NC2 compressor.

The units are supplied to meet standard conditions but there is capacity within the system to accommodate customers specialised electrical or pneumatic control requirements.

Remote controls are available as an optional extra.

Specification	
Max. Pressure: 1.4 Kg/cm <sup>2</sup>	Output: 65 litres/minute at 0.7Kg/cm <sup>2</sup>
Weight: 34 Kgs.	Size: 400 x 395 x 370mm high
NC3/230 for 220/240v AC	Overload Protection: MCB
Single phase supply	Current: 2 amps
NC3/12 For 12v DC supply	Current: 30 amps
NC3/24 For 24v DC supply	Current: 16 amps



## Remote Controls

This "three position" switch is for the remote control of compressors. It enables the mast to be extended, retracted or held at any height. It may be hand held for DC powered compressors or mounted onto the vehicle instrument panel for both AC and DC powered units. The switch is fitted into an ABS enclosure and supplied complete with 4 metres of cable and a weatherproof plug and socket. It activates a relay and a solenoid operated air valve inside the compressor. These switches should be ordered with the compressor but can be supplied in kit form for retrofitting to non-remote units.



### RC/1

This "three button" relay interfaced unit has been primarily designed for exterior applications and incorporates a low voltage DC converter. The control has separate commands to extend, hold or retract mast. The push buttons are fitted into die cast housing with an environmental protection rating of IP65 and supplied complete with 4 metres of cable and a weatherproof plug and socket. The controller may also be used to control a relay interface for DC driven compressors. These remote controls must be ordered with the compressor.



### RC/2

## Foot Pumps

General use twin cylinder foot pump fitted with pressure gauge, hose and special mast connector. With average speed of pumping, NK Series masts can be extended at approx. 5 metres per minute and NH Series at 8 metres per minute.

### NFP/1



# Installation Dimensions

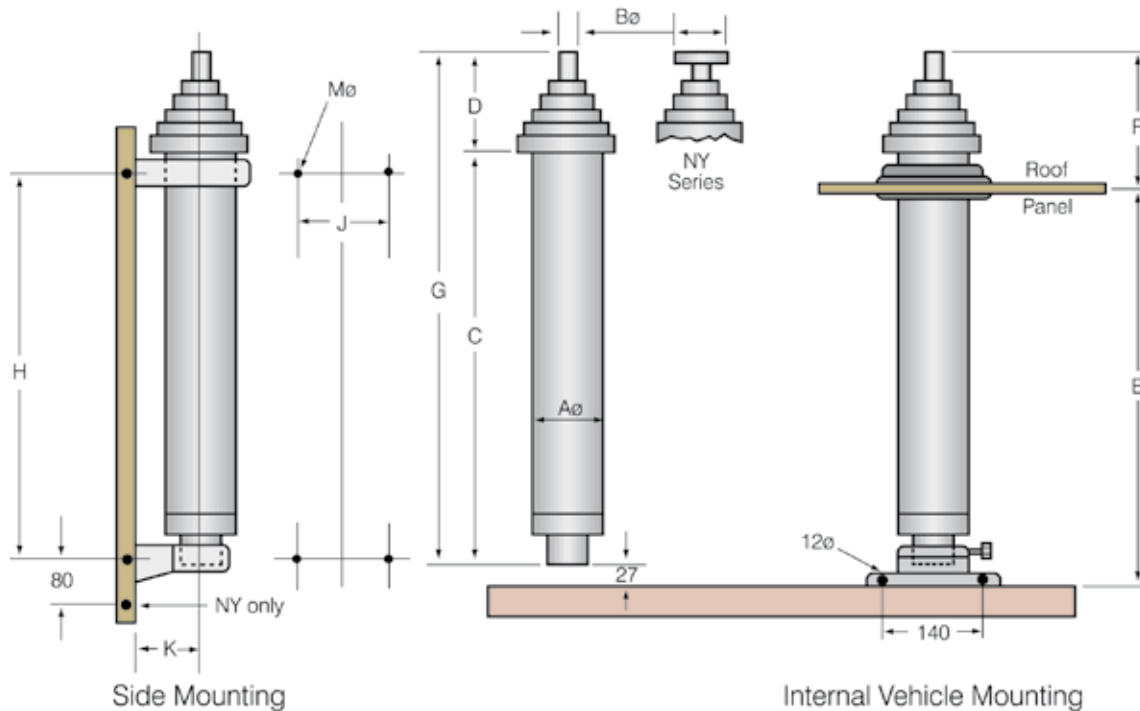

Mast	A dia.	B dia.	C	D	E min.	E max.	F min.	G	H min.	H max.	J	K	M dia.
NH.5	89	38	1161	252	800	1125	315	1413	800	1100	150	108	10
NH.7	89	38	1586	252	1000	1550	315	1838	1000	1530	150	108	10
NH.9	89	38	2043	252	1200	1955	315	2268	1200	1990	150	108	10

NK.6	102	50	1361	277	900	1325	340	1638	900	1300	150	108	10
NK.9	102	50	2026	277	1300	1990	340	2303	1300	1970	150	108	10
NK.11	102	38	2026	340	1300	1990	403	2366	1300	1970	150	108	10
NK.16	102	50	3736	277	2000	3700	340	4013	2000	3680	150	108	10

NL.8	127	50	1368	403	900	1332	466	1771	900	1300	150	108	10
NL.9	127	50	2033	407	1300	1997	470	2440	1300	1980	150	108	10
NL.10	127	50	2033	470	1300	1997	533	2503	1300	1980	150	108	10
NL.12	127	50	2033	403	1300	1997	466	2436	1300	1980	150	108	10
NL.16	127	50	3743	407	2000	3707	470	4150	2000	3680	150	108	10
NL.22	127	50	3743	403	2000	3707	466	4146	2000	3680	150	108	10

NX.8	152	50	1375	533	900	1339	596	1908	900	1300	160	130	12
NX.10	152	50	2040	470	1300	2004	533	2510	1300	1960	160	130	12
NX.14	152	50	2040	596	1300	2004	659	2636	1300	1960	160	130	12
NX.18	152	50	3850	470	2000	3814	533	4320	2000	3770	160	130	12
NX.25	152	50	3850	596	2000	3814	659	4446	2000	3770	160	130	12
NX.30	152	50	4040	529	2200	4004	592	4569	2200	3960	160	130	12

NY.7	238	150	1381	282	900	1343*	347	1663	900	1300*	200	180	12
NY.10	238	150	2026	239	1300	1988*	304	2265	1300	1950*	200	180	12
NY.12	238	150	2026	325	1300	1988*	390	2351	1300	1950*	200	180	12
NY.14	238	150	2026	368	1300	1988*	433	2394	1300	1950*	200	180	12
NY.18	238	150	3756	239	2000	3718*	304	3995	2000	3680*	200	180	12
NY.21	238	150	3756	282	2000	3718*	347	4038	2000	3680*	200	180	12

FM.5	115	108	1369	232	900	1317	311	1601	900	1317	150	120	10
FM.6	115	108	1762	232	1100	1710	311	1994	1100	3710	150	120	10
FM.8	115	108	2052	232	1300	2000	311	2284	1300	2000	150	120	10

NOTE: All dimensions in mm. NLC not shown.

\*Dimension will decrease by 68mm for non rotating base plate.

## Pneumatic Mast Trailers

SMC manufacture a standard range of on and off road trailers, capable of supporting masts up to 30 metres high to their maximum wind speed capability and special units tailored for individual projects, with different towing arrangements.

All standard models can be towed by a car, preferably 1600cc or more, with a 50mm dia. ball hitch.

### Standard trailer specification:

- » Fully galvanised, two wheeled trailer complete with:
- » Mast tilting frame (with winch where necessary)
- » Aluminium chequer plate deck
- » Telescopic outriggers with wind-down legs
- » Overrun brakes with hand brake
- » 50mm ball hitch with safety stop and jockey wheel
- » 7 pin trailer plug
- » Regulation lights, indicators and reflectors on tailboard
- » Spare wheel and wrench supplied as standard



The Hilomast range that we recommend for fitting to trailers is as follows:

**Trailer NL/SHORT.** Designed for all masts up to 3 metres retracted, maximum 14 metres extended, except NY series.

Trailer dimensions : 2.85m. X 1.5m. X 1.37m. high.

**Trailer NL/LONG.** For longer NK and NL masts up to 22 metres.

Dimensions : 4.8m. X 1.85m. X 1.99m. high.

Available in rugged construction for off-road usage.

**Trailer NX/LONG.** For longer NX masts up to 30 metres.

Dimensions : 4.8m. X 1.85m. X 2.03m. high.

Available in rugged construction for off-road usage.

**WTM trailer.** For winched masts WTM/1, 2 and 3 only.

Dimensions : 5.48m. X 1.94m. X 2.7m. high.

Available in rugged construction for off-road usage.

**Trailer HD/NY.** For individual NY masts, dimensions vary according to mast carried.

These larger/heavier trailers should be towed by a Land Rover or larger type of vehicle.



## Vehicle Installation



SMC provide a professional installation service, fitting masts in vehicles from light vans to 4wd heavyweights. We can also supply and fit supporting equipment, including split charge systems, inverters, lighting, distribution, storage and workbenches.

We will plan, advise and execute the installation from our own workshops and if necessary tailor make any fittings required. Hilomasts from 16 metres extended are usually more than four metres long retracted, so transportation and weight become a problem for the operator.

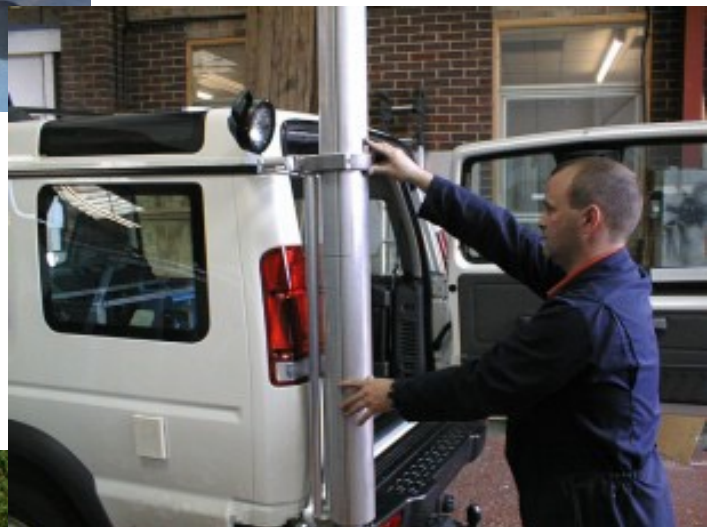

The roof carriage system shown to left is for long masts to be carried horizontally, tilting to vertical for operation. Fabricated from plated steel it incorporates a roof rack that can have deck access to the mast and extra storage space.

Hilomasts can also be fitted vertically in vehicles using a thru the roof system, incorporating the SMC roof bearing kit.



## Rapid Deployment Unit

The SMC Rapid deployment option is a very practical way of fitting the Hilomast to a mobile unit without making it a permanent feature.

Simply carry the mast on the roof rack and upon arrival at the specified location, bolt the specially designed brackets to the vehicle and secure with the foot piece.

This system allows the rapid deployment of masts up to a maximum of 12 metres.



Easily clamps to the vehicle's gutter or to a vehicle roof rack.

The adjustable bars allow fitting of the mast to most sizes of vehicle.



Vehicle weight holds the foot of the mast in place, whilst the swivel foot allows adjustment of aerial or lamp direction.

# Winch Operated Telescopic Hilomast

## WTM Series

- » Robust construction - mast sections constructed from heat treated aluminium alloy
- » Full length splines prevent relative rotation
- » Sections extended simultaneously by stainless steel rope system
- » Specially designed hand or electric winch featuring:
  - Disc brake
  - Noiseless operation
  - Fully machined involute gears for smooth operation

Mast	Height Extended		Height Retracted		Number of Sections	Diameter of Top Sections	Vertical Head Load	Horizontal Head Load	Max. wind Speed Un-guyed	Basic Weight of Mast
	M	ft	M	ft						
WTM/1	13	43	5.37	17.62	3	102	50	23	130	80
WTM/2	17	57	5.48	18.00	4	76	45	16	96	92
WTM/3	21	70	5.63	18.46	5	50	20	10	80	102
WTM/4	9	29	2.98	9.78	4	76	55	38	160	62

Calculations on side surface area of 2200cm<sup>2</sup>

All of the WTM series have a bottom section diameter of 152mm. The spigot supplied for mounting antennas is 50mm diameter and 150mm long, unless specified otherwise when ordered. It is suitable for most types of rotators.

## WTM Series

These masts will support large 3 element antennas, providing that the maximum operating heights specified in this table are not exceeded. The figures are for a typical antenna with a boom length of 4.3 metres (14 ft) and element length of 8.2 metres (27 ft) giving wind loads of 45kgs (100 lbs) at 36m/sec (80mph).

### WTM/1 and WTM/2

These masts will support large 3 element antennas, providing that the maximum operating heights specified in this table are not exceeded. The figures are for a typical antenna with a boom length of 4.3 metres (14 ft) and element length of 8.2 metres (27 ft) giving wind loads of 45kgs (100 lbs) at 36m/sec (80mph).

Wind Speed (Unguyed)	25m/sec. 55 mph	31.5m/sec. 70 mph	36m/sec. 80 mph	45m/sec. 100 mph
WTM/1	Fully Extended 13m (43 ft)	Fully Extended 13m (43 ft)	Retract to 11m (36 ft)	Retract to 9m (29 ft)
WTM/2	Fully Extended 17m (56 ft)	Retract to 13m (43 ft)	Retract to 11m (36 ft)	Retract to 9m (29 ft)

### WTM/3

This mast is intended for smaller antennas, where maximum height is of prime importance. It is particularly useful for experimental work and field strength measurement. However, if under extremely windy conditions, the operating heights are reduced to those shown in the above table, it will withstand the same wind loading as the WTM/2 mast.

This mast has been developed to withstand high head loads at heights of up to 9 metres. It will safely support a 0.6m (2 ft) diameter dish at a wind speed of 160 kph or a 1.0m (3 ft) diameter dish at a wind speed of 100 kph. It has a retracted length of only 2.98m (9.78 ft), making it ideally suitable for fitting to the rear of telecommunications vehicles.

A 2.0 metre extension is available if required.

Due to the wide variety of applications and methods of mounting, the masts are manufactured as basic units. It is therefore, necessary when ordering to specify the type of mast, type of winch, mounting arrangement and accessories required.



## Ideal for mobile telecommunications systems

- » Incorporates 4 telescopic outriggers with wind-down legs
- » Complete stability
- » Robust construction and designed for easy shipment
- » Standard tilt-over mount WTO/I, complete with hand winch
- » Optional power winch available for mast extension
- » Can be erected by just one person
- » Quick operation - from parking the vehicle to fully extended mast takes just 15 minutes

Construction	Steel
Finish	Hot dip galvanised
Overall width	1.94m (6.4 ft)
Overall length	5.48m (18 ft)
Overall height	2.70m (8.9 ft)
Total weight of trailer	620 kgs
Spare carrying capacity	500 kgs
Suspension	Single axle cross beam
Tyres	165 x 13 radial
Brakes:	Overrun brake system with 8" dia. drums and parking break
Coupling	50mm dia. ball
Floor	Partially covered for adequate operating space.
Lighting	Fitted with lights and reflectors to comply with legal requirements. Standard 7 pin trailer plug supplied
Optional	Equipment box, suitable for battery and other equipment



## Accessories

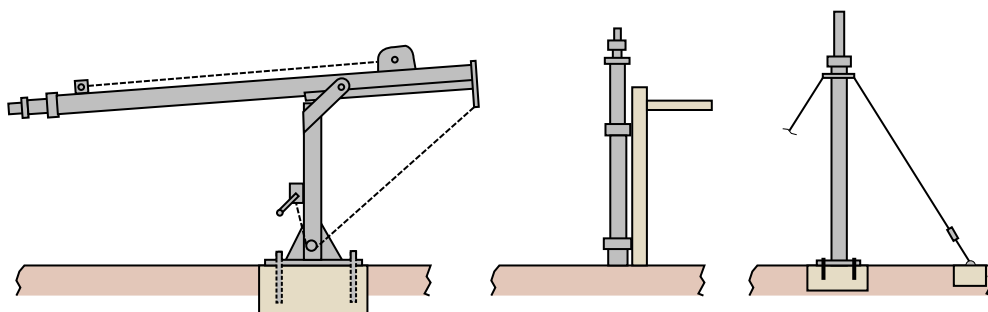

## Tilt Over Mechanism

To give easy access for fitting and servicing antennas. Of galvanised steel construction with winch incorporating safety device and galvanised steel wire rope. The mast carrier is also of galvanised steel, pivoted at the top and complete with clamps. The mast can be easily removed from the carrier for use in other locations.

The unit is supplied complete with foundation bolts and bolt setting template. The size of the foundation block is 1.2 metres square x 0.75 metres deep. The tilt-over mechanism is also suitable for reinforced flat roofs on airport buildings, radio stations etc. Weight 110 kgs. (Not suitable for WTM/4) .

WTO/1

## Base Guy Assembly

Comprising: special collar, 3 galvanised steel wire guys with adjusting screws, ground stakes, ground pegs and base plate. Can be set in concrete for permanent sites.

**WTT**

## Side Mounting Brackets

For mounting masts to vertical surfaces of vehicles or buildings. Comprising two aluminium alloy castings, giving full protection to the mast tube, bolted to galvanised steel bars formed to give a distance of 260mm between the centre of the mast and the mounting face. (Hole centres are 460mm. apart for M12 bolts).

These brackets are not designed to support the weight of the mast, which should stand on its base.

**WTB**

## Hand Winch

A manual winch of steel construction, with an adjustable handle for lifting varying loads with surprisingly little effort. This winch is suitable for all of the WTM series of masts. The lifting mechanism is covered for environmental protection. The friction brake is automatic and self locking to avoid 'back-winding' and it will maintain whatever height the mast reaches when the operator stops winding.

**WTH/1**

## Electric Winch

This electric winch is driven by a robust 12v DC motor with limit switches set to automatically operate at the desired minimum and maximum mast heights. When connected to a standard 12v vehicle battery it takes approx 6 mins to fully extend the tallest mast in the series.

There is a two button control for up/down operation, which stops when the button is released. This winch can also be operated manually with the handle provided, in the event of a power failure. The spooled drum prevents the wire rope from bunching and ensures smooth and controlled operation. The winch is weather protected to Standard IP54

**WT12/1**

## Extension Tube for WTM/1

This tube is 76mm. dia. and extends the mast height by 4m. (131/2ft.).

The wind loadings and headloads must be reduced to those for the WTM/2 mast.

**WTE/1**

## Extension Tube for WTM/2

This tube is 51mm. dia. and extends the mast height by 2m. (61/2 ft.).

**WTE/4**

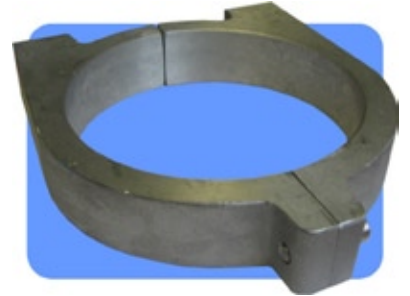

# HiloCAM<sub>2</sub>

Developed by Photographers for Photographers

For 50 years South Midlands Communications has been manufacturing telescopic masts for endless applications. The development in recent years has moved into providing our customers with a single source complete packaged system.

The combination of experience in designing and building masts and in-house photographic knowledge produced the **HiloCAM** system. Further developing these ideas and listening to our customers desires produced the **HiloCAM<sub>2</sub>**, a fully remote controlled digital SLR aerial photography system.

Controlling and shooting aerial photographs couldn't be simpler!



# The System



## Robustly Built For The Demanding Marketplace

Spent lots of money on your camera? Don't risk losing your investment by cutting corners.

The **HiloCAM<sub>2</sub>**, from South Midlands Communications provides the ideal platform for your digital SLR. Using a strong yet lightweight die cast aluminium pan and tilt unit gives you confidence to deploy your camera on top of a mast up to staggering heights of 100ft.

## Pan/Tilt, Zoom, Compose And Shoot, Simplicity At Your Fingers

The new **HiloCAM<sub>2</sub>** system incorporates a 3-axis joystick, which allows you to pan, tilt and zoom the camera system using one hand. Compose and shoot your image using the LCD display, which gives a live video feed looking through the viewfinder.



Connecting the controller via the USB cable to your computer automatically transfers images to your desktop during your photo shoot for fast on-site post processing and printing.



## Shoot RAW Using The Latest Digital SLR

Using the latest Canon and Nikon Digital SLR cameras can have fully motorised zoom capabilities along with the 10 million pixel resolution already offered by these models. Outstanding results can be achieved with this combination.

*Due to ever changing camera technologies compatible camera's are always changing, contact us for a list of system compatibilities.*

# The professional solution

South Midlands Communications Ltd  
SM House, School Close, Chandlers Ford Industrial Estate,  
Eastleigh, Hampshire, SO53 4BY ENGLAND  
Tel: +44 (0)23 8024 6200 Fax: +44 (0)23 8024 6206  
Email: [sales@smc-comms.com](mailto:sales@smc-comms.com) Web: [www.smc-comms.com](http://www.smc-comms.com)

400  
DIGITAL

# Typical Mast Applications

Aerial Photography



Incident Response



Military



Broadcasting



Monitoring



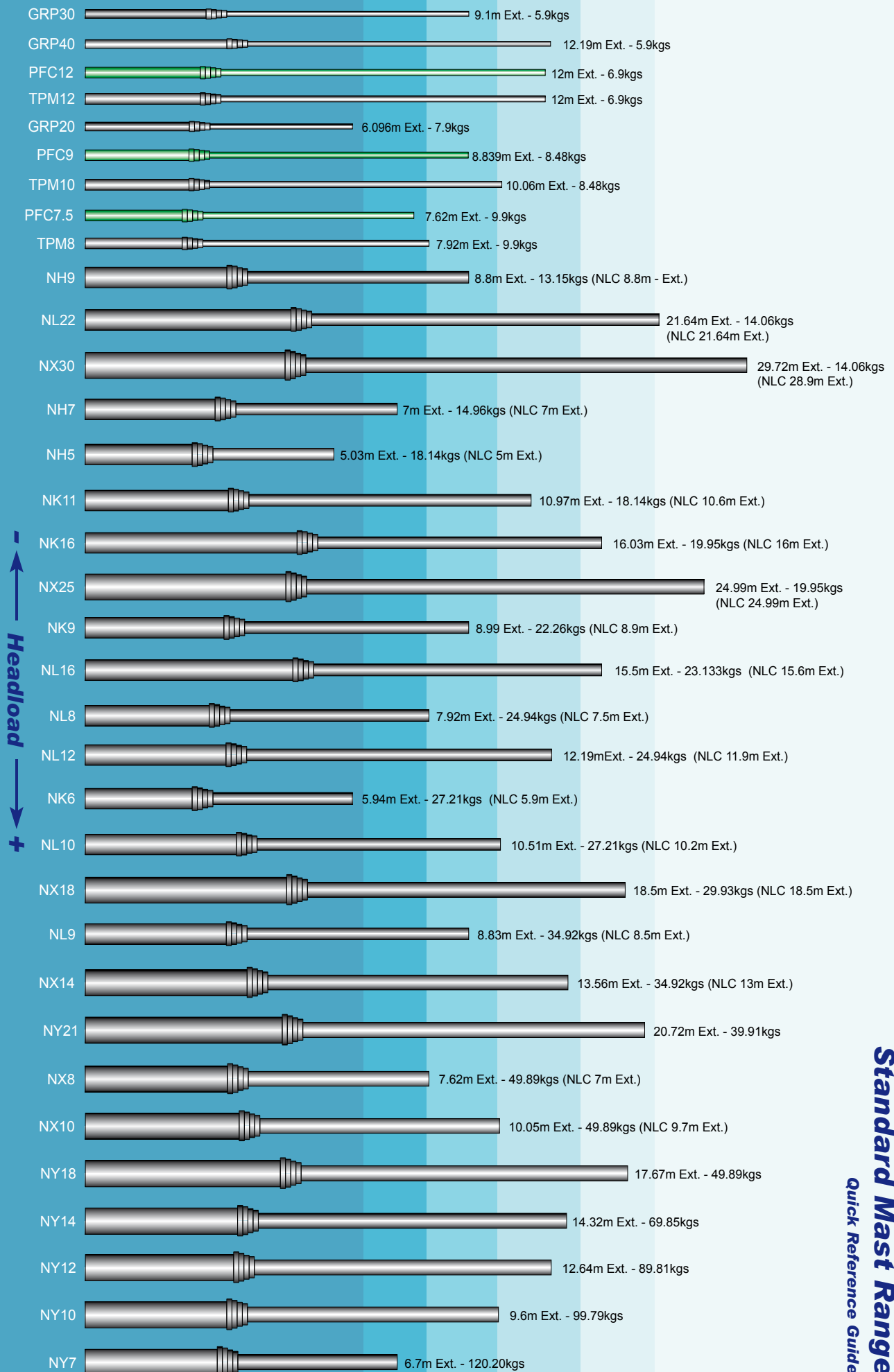

**Standard Mast Range**  
Quick Reference Guide

# Standard Mast Quick Reference Details

Mast	Height Extended	Height Retracted	Number Of Sections	Diameter Of Top Section	Diameter Of Base Section	Vertical Headload	Max. Wind Speed Unguyed	Max. Wind Speed With Top Guys	Basic Weight Of Mast
	(m)	(m)		(mm)	(mm)	(kgs)	(kph)	(kph)	(kgs)
NH5	5.0	1.41	5	38	89.0	18	180	180	15
NH5-NLC	5.0	1.41	5	38	89.0	18	180	180	15
NH7	7.0	1.84	5	38	89.0	15	135	160	19
NH7-NLC	7.0	1.84	5	38	89.0	15	135	160	19
NH9	9.0	2.30	5	38	89.0	13	108	147	23
NH9-NLC	9.0	2.30	5	38	89.0	13	108	147	23
NK6	5.9	1.64	5	50	102	27	164	164	21
NK6-NLC	5.9	1.60	5	50	102	27	164	164	21
NK9	9.0	2.30	5	50	102	22	114	137	26
NK9-NLC	8.9	2.30	5	50	102	22	114	137	26
NK11	10.9	2.37	6	38	102	18	96	125	29
NK11-NLC	10.6	2.37	6	38	102	18	96	125	29
NK16	16.0	4.00	5	50	102	20	65	112	44
NK16-NLC	16.0	4.00	5	50	102	20	65	112	44
NL8	7.9	1.77	7	50	127	25	140	140	34
NL8-NLC	7.5	1.77	7	50	127	25	140	140	34
NL9	8.8	2.44	5	76	127	35	130	130	37
NL9-NLC	8.5	2.44	5	76	127	35	130	130	37
NL10	10.5	2.50	6	63	127	27	110	120	41
NL10-NLC	10.2	2.30	6	63	127	27	110	120	41
NL12	12.2	2.43	7	50	127	25	95	110	46
NL12-NLC	11.9	2.40	7	50	127	25	95	110	46
NL16	15.6	4.15	5	76	127	23	78	102	61
NL16-NLC	15.6	4.00	5	76	127	23	78	102	61
NL22	21.7	4.15	7	50	127	14	56	92	74
NL22-NLC	21.7	4.10	7	50	127	14	56	92	74
NX8	7.6	1.91	7	76	152	50	155	155	50
NX8-NLC	7.0	1.69	7	76	152	50	155	155	50
NX10	10.1	2.51	6	89	152	50	120	120	60
NX10-NLC	9.7	2.31	6	89	152	50	120	120	60
NX14	13.6	2.64	8	63	152	35	92	95	70
NX14-NLC	13.0	2.40	8	63	152	35	92	95	70
NX18	18.5	4.32	6	89	152	30	70	83	93
NX18-NLC	18.5	4.18	6	89	152	30	70	83	93
NX25	25.0	4.44	8	63	152	20	52	80	110
NX25-NLC	25.0	4.31	8	63	152	20	52	80	110
NX30	29.8	4.57	9	50	152	14	44	75	120
NX30-NLC	28.9	4.44	9	50	152	14	44	75	120
NY7	6.7†	1.62	7	114	238.00	120	150	*	88
NY7-NLC	6.7†	1.62	7	114	238.00	120	150	*	88
NY10	9.60†	2.22	6	127	238.00	100	126	*	106
NY12	12.7†	2.31	8	102	238.00	90	90	*	120
NY14	14.3†	2.35	9	89	238.00	70	80	*	127
NY18	17.†	3.96	6	127	238.00	50	83	*	170
NY21	20.7†	4.00	7	114	238.00	40	67	*	183
BR25	7.6	1.80	6	89.9	152	68	146	*	50
BR30	9.1	2.10	6	89.9	152	50	120.0	*	54
BR42	12.8	2.15†	9	89.0	229	68	101	*	120
BR48	14.6	2.6†	8	102	229	91	90	*	127
BR52	15.8	2.6†	9	89.9	229	79	72	*	136
BR56	17.0	2.9†	8	102	229	91	79	*	149
TPM8	8.0	1.47	8	31.75	73.66	10	N/A	120	10.2
TPM10	10.0	1.75	8	31.75	73.66	8.5	N/A	100	11.61
TPM12	12.0	2.02	8	31.75	73.66	7	N/A	85	12.7
GRP20	6.1	1.65	4	31.8	50.8	8.00	-	-	3.00
GRP30	9.17	2.28	5	31.75	57	6	-	-	6
PFC7.5	7.5	1.93	5	65.6	85.6	12	N/A	120	6
PFC9	9.0	2	6	60.6	85.6	10	N/A	100	7
PFC12	12.0	2.1	8	50.6	85.6	9	N/A	85	9

† with non rotating base

\* top guys not recommended



South Midlands Communications Ltd  
S.M House, School Close  
Chandlers Ford Industrial Estate  
Hampshire  
SO53 4BY  
UNITED KINGDOM

Tel: +44 (0)23 8024 6200  
Fax: +44 (0)23 8024 6206  
Email: [sales@smc-comms.com](mailto:sales@smc-comms.com)  
[www.smc-comms.com](http://www.smc-comms.com)